



# **Electronic Publication of Patents Journal under The Patents (Amendments) Act, 2016**

Weekending:- 23-09-2016

Legal Publication Date:- 03-10-2016

Journal Code (161003)

## NEW APPLICATIONS FOR THE PATENTS

The dates shown in the crescent brackets are the dates claimed under section 86 of the Patents Ordinance 2000.

<b>20-09-2016</b>		
562/2016	F. HOFFMANN-LA ROCHE AG. Switzerland (Priority 24-09-2015 EP)	“NEW BICYCLIC COMPOUNDS AS DUAL ATX/CA INHIBITORS”
563/2016	F. HOFFMANN-LA ROCHE AG. Switzerland (Priority 24-09-2015 EP)	“NEW BICYCLIC COMPOUNDS AS ATX INHIBITORS”
564/2016	F. HOFFMANN-LA ROCHE AG. Switzerland (Priority 24-09-2015 EP)	“NEW BICYCLIC COMPOUNDS AS DUAL ATX/CA INHIBITORS”
565/2016	Yuan-Cheng CHIEN Taiwan (Priority 24-06-2016 TW)	“SANITARY NAPKIN”
566/2016	Bechtel Hydrocarbon Technology Solutions, Inc. U.S.A. (Priority 21-09-2015 US)	“DELAYED COKE DRUM QUENCH SYSTEMS AND METHODS HAVING REDUCED ATMOSPHERIC EMISSIONS”
567/2016	BAYER PHARMA AKTIENGESELLSCHAFT, Germany Fed.Rep (Priority 08-10-2015 EP)	“NOVEL MODIFIED MACROCYCLIC COMPOUNDS”
568/2016	BAYER PHARMA AKTIENGESELLSCHAFT, Germany Fed.Rep (Priority 29-09-2015 CN)	“NOVEL MACROCYCLIC SULFONDIIMINE COMPOUNDS”

21-09-2016		
569/2016	Syngenta Participations AG. Switzerland (Priority 23-09-2015 EP)	"INSECTICIDAL COMPOUNDS"
570/2016	F. HOFFMANN-LA ROCHE AG. Switzerland (Priority 24-09-2015 EP)	"NEW BICYCLIC COMPOUNDS AS ATX INHIBITORS"
571/2016	Syngenta Participations AG. Switzerland (Priority 23-09-2015 EP)	"INSECTICIDAL COMPOUNDS"
572/2016	BOEHRINGER INGELHEIM INTERNATIONAL GmbH, Germany Fed.Rep (Priority 17-10-2003 DE) <b>Divisional</b>	"Process for preparing amino crotonyl compound"
22-09-2016		
573/2016	UNILEVER PLC, United Kingdom (Priority 01-10-2015 EP)	"POWDER LAUNDRY DETERGENT COMPOSITION"
574/2016	CHT R. Beitlich GmbH Germany Fed.Rep (Priority 25-09-2015 DE)	"Textile Fabrics with Denim-like Features"
575/2016	Dr. Ghulam Abbas, Dr. M. Jawad Asghar, Muhammad Rizwan and Fiaz Ahmad Pakistan	"A process for genetic improvement in nutritional quality of mungbean by enriching its amino acid profile and protein content through recombination with mashbean"
576/2016	LOTTE CONFECTIONERY CO.,	"Center-filled chewing gum composition"

	LTD. Rep.of Korea (Priority 24/09/2015 KR)	without leak of syrup”
<b>23-09-2016</b>		
577/2016	SICPA HOLDING SA. Switzerland (Priority 24-09-2015 EP)	“REMOTE MARK PRINTING ON A SECURITY DOCUMENT”
578/2016	SICPA HOLDING SA. Switzerland (Priority 24-09-2015 EP)	“CERTIFICATION OF ITEMS”
579/2016	SICPA HOLDING SA. Switzerland (Priority 24-09-2015 EP)	“REMOTE SECURITY DOCUMENT ANALYSIS”
580/2016	SICPA HOLDING SA. Switzerland (Priority 24-09-2015 EP)	“REMOTE PASSPORT AND SECURITY DOCUMENT MARKING”
581/2016	GENENTECH, INC U.S.A. (Priority 25-09-2015 US)	“ANTI-TIGIT ANTIBODIES AND METHODS OF USE”
582/2016	GENENTECH, INC U.S.A. (Priority 23-09-2015 US)	“OPTIMIZED VARIANTS OF ANTI-VEGF ANTIBODIES”
583/2016	AstraZeneca AB., Sweden (Priority 25-09-2015 US)	“Compounds and Methods for Inhibiting JAK”

**APPLICATION ACCEPTED**

Notice is hereby given that the person interested in opposing the grant of Patents to any of the applications referred to below at any time within four months from the date of this Gazette may give notice at the Patent Office on the prescribed Form P-7 of the Patents Rules 18(1) of 2003.

The six figures number shown in the right hand side are those given to applications on acceptance of the complete specification under which the specification will be printed and subsequent proceeding taken.

The figures shown within square brackets after the title of inventions indicate their classification index at acceptance.

Typed copies of the specification which are to open to public inspection can be supplied by the Patent Office on payment of the prescribed charges which may be ascertained on application to the office.

358/2007	NOKIA TECHNOLOGIES OY. Finland.	"Apparatus for improving call setup speed between compliant systems"  H04L29/06.  <b>142422</b>  A method for providing fast and flexible call setup, the method comprising establishing a plurality of phantom channels over a bearer channel, wherein at least one of the plurality of phantom channels is pre-assigned to a first session negotiation method, at least one of remaining phantom channels of the plurality of phantom channels is pre- assigned to a second session negotiation method, the second session negotiation method has at least one property different from the first session negotiation method, and at least one of the remaining phantom channels is assigned to at least one fixed media operation point, whereby the first session negotiation method is utilized for
----------	---------------------------------------	------------------------------------------------------------------------------------------------------------------------------------------------------------------------------------------------------------------------------------------------------------------------------------------------------------------------------------------------------------------------------------------------------------------------------------------------------------------------------------------------------------------------------------------------------------------------------------------------------------------------------------------------------------------------------------------------------------------------------------------------------------------------------------------------------------------------------------------------------------------------------

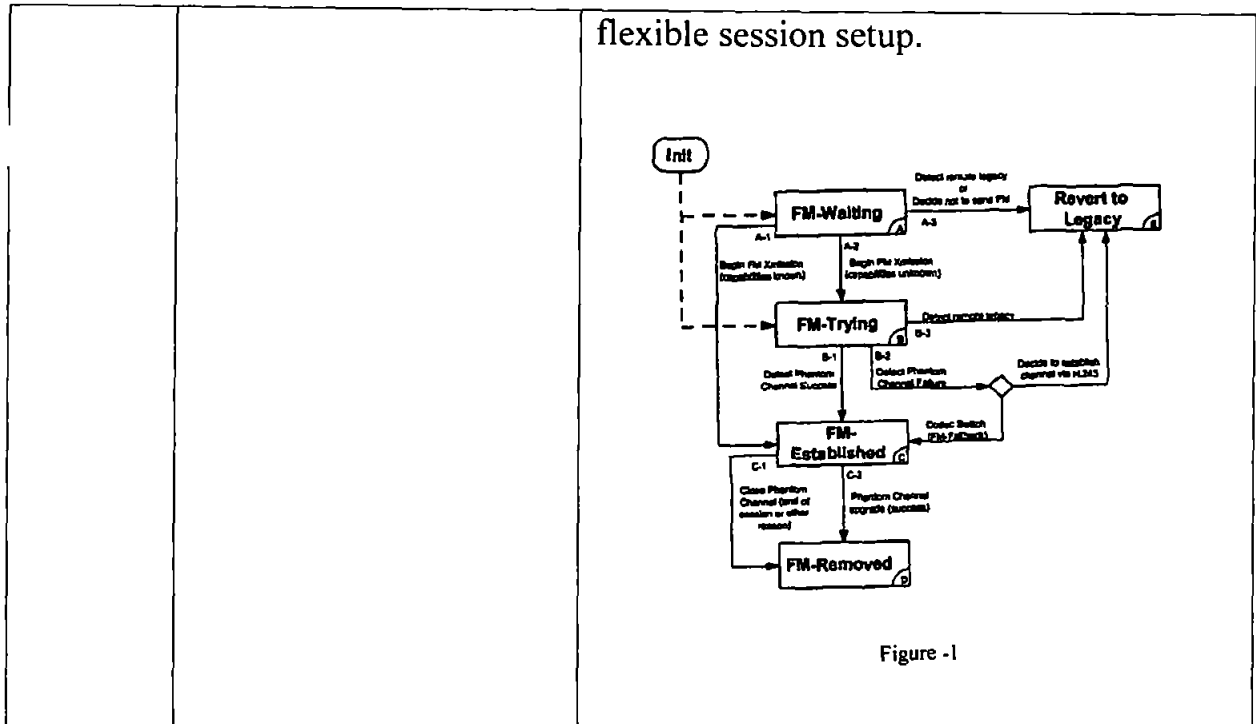

351/2010 SAIPEM S.p.A., Italy.

"TUBE BUNDLE EQUIPMENT WITH LIQUID FLOW REGULATOR ELEMENTS"

F28F25/06 and F28D3/02.

**142423**

The present invention relates to Tube-bundle equipment of the falling liquid film type, comprising a vertical cylindrical body closed at the ends and divided into at least an upper section(1), an intermediate section(3) and a lower section(2) by means of two perforated tube sheets(15, 106, 206,16) arranged transversally to support the tubes forming the bundle, wherein each of said tubes(4,11) is surmounted, on the upper end, by a ferrule (5, 102) , for the inlet and distribution of the liquid in the form of a film,which comprises in the upper part, one or more openings(103,203) for the outlet of vapours,at an intermediate height one or more openings

(204,104), preferably tangential, for the inlet of the liquid and below, a circular base(216) for resting on said tube(4,111) from which an internal cylindrical section (215), inserted in the tube for a length varying from 10 to 200 mm, protrudes downwards together with an outer metallic strip for a length of at least 2 mm, so that, in the circular area defined between said outer metallic strip (214) and said protruding cylindrical section(215), there is a gasket(213), inserted between said circular base(216) of the ferrule(5,102) and said upper edge of the tube.

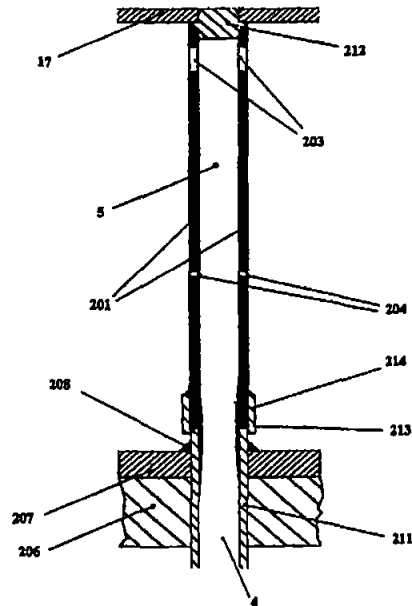

128/2015 Saurer Germany GmbH & Co. KG. (Germany)

"WORKSTATION OF A TEXTILE MACHINE WITH A WAXING DEVICE"

B65H71/00.

**142424**

The present invention relates to a workstation (12) of a textile machine with a waxing device (20) for a thread (2), wherein the waxing device (20) comprises a receiving mandrel (21) for a paraffin wax body (22) and the thread (2), for waxing

thereof, is guided above or below the paraffin wax body (22) and to the side of the receiving mandrel (21), and the workstation (12), viewed in the running direction of the thread (2), has an upstream thread guide element (5, 25) directly before the waxing device (20) and a thread traversing device (6) after said waxing device (20), characterised in that, in relation to the centre plane of the thread traversing brought about by the thread traversing device (6), the receiving mandrel (21) is offset laterally in the same direction as the thread (2) with respect to the receiving mandrel (21), or in that, in relation to the centre plane of the thread traversing brought about by the thread traversing device (6), the upstream thread guide element (5, 25) is offset laterally in the opposite direction to the thread (2) with respect to the receiving mandrel (21).

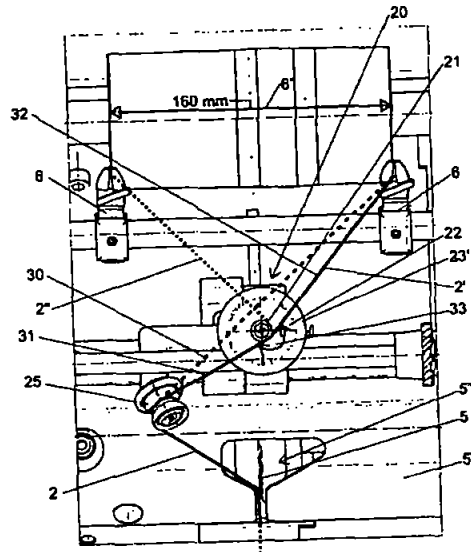



**CORRIGENDUM**

In the Gazette of Pakistan Part-V issued dated **05-04-2016**, under the Heading “APPLICATION ACCEPTED”. The following correction is as under:-

**APPLICATION ACCEPTED**  
(Change Application No. against Serial No.142326 only)

For : 1321/2007

Read : 488/2013

**NEW APPLICATIONS FOR THE INDUSTRIAL DESIGNS**

S. No.	Design No.	Title & Class	Applicant
<b><u>19/09/2016</u></b>			
1.	18431	Plate (Class-03)	Dove Melamine ware
<b><u>20/09/2016</u></b>			
2.	18432	Mini Junior Bag Pipe (Class-12)	M/s. Khalid Mehmood Butt, Tariq Mehmood, Adnan Butt, Irfan Khalid All Being Partners. M. Khalid Pipe Co.
<b><u>21/09/2016</u></b>			
3.	18433	Kettle Bell (Junior) (Class-12)	Tempo Enterprises,
4.	18434	Fine Liner Pen (Class-03)	Indus Pencil Industries (Pvt.) Limited,
5.	18435	Fountain Pen (Class-03)	Indus Pencil Industries (Pvt.) Limited,
<b><u>22/09/2016</u></b>			
6.	18436	Hot Pot (Class-03)	Shoaibee Industries,
7.	18437	Cab-F510 (Class-01)	Yunnan Lifan Junma Vehicles Co. Ltd.
8.	18438	Truck-F510 (Class-01)	Yunnan Lifan Junma Vehicles Co. Ltd.
<b><u>23/09/2016</u></b>			
9.	18439	Boxes (Class-05)	KYB Corporation,(a Japanese Corporation)
10.	18440	Boxes (Class-05)	KYB Corporation,(a Japanese Corporation)



**(Dr. Muhammad Fayyaz Ahmad)**  
Controller of Patents  
& Registrar of Designs  
Ph: 99215488